

MC34063A MC33063A

DC-to-DC Converter Control Circuits

The MC34063A Series is a monolithic control circuit containing the primary functions required for DC-to-DC converters. These devices consist of an internal temperature compensated reference, comparator, controlled duty cycle oscillator with an active current limit circuit, driver and high current output switch. This series was specifically designed to be incorporated in Step-Down and Step-Up and Voltage-Inverting applications with a minimum number of external components. Refer to Application Notes AN920A/D and AN954/D for additional design information.

- Operation from 3.0 V to 40 V Input
- Low Standby Current
- Current Limiting
- Output Switch Current to 1.5 A
- Output Voltage Adjustable
- Frequency Operation to 100 kHz
- Precision 2% Reference

DC-to-DC CONVERTER CONTROL CIRCUITS

SEMICONDUCTOR TECHNICAL DATA

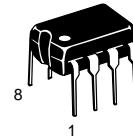

P, P1 SUFFIX
PLASTIC PACKAGE
CASE 626



D SUFFIX
PLASTIC PACKAGE
CASE 751
(SO-8)

Representative Schematic Diagram

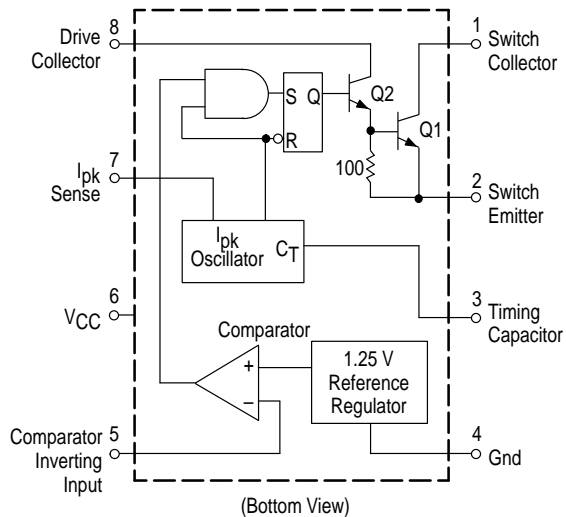

This device contains 51 active transistors.

PIN CONNECTIONS

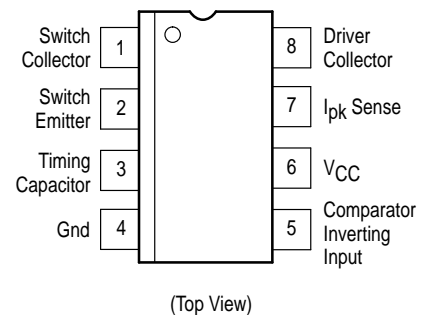

ORDERING INFORMATION

Device	Operating Temperature Range	Package
MC33063AD	$T_A = -40^\circ \text{ to } +85^\circ \text{C}$	SO-8
MC33063AP1		Plastic DIP
MC33063AVD	$T_A = -40^\circ \text{ to } +125^\circ \text{C}$	SO-8
MC33063AVP		Plastic DIP
MC34063AD	$T_A = 0^\circ \text{ to } +70^\circ \text{C}$	SO-8
MC34063AP1		Plastic DIP

MC34063A MC33063A

MAXIMUM RATINGS

Rating	Symbol	Value	Unit
Power Supply Voltage	V_{CC}	40	Vdc
Comparator Input Voltage Range	V_{IR}	-0.3 to +40	Vdc
Switch Collector Voltage	$V_{C(\text{switch})}$	40	Vdc
Switch Emitter Voltage ($V_{P_{in\ 1}} = 40\text{ V}$)	$V_{E(\text{switch})}$	40	Vdc
Switch Collector to Emitter Voltage	$V_{CE(\text{switch})}$	40	Vdc
Driver Collector Voltage	$V_{C(\text{driver})}$	40	Vdc
Driver Collector Current (Note 1)	$I_{C(\text{driver})}$	100	mA
Switch Current	I_{SW}	1.5	A
Power Dissipation and Thermal Characteristics Plastic Package, P, P1 Suffix $T_A = 25^\circ\text{C}$ Thermal Resistance	P_D $R_{\theta JA}$	1.25 100	W $^\circ\text{C/W}$
SOIC Package, D Suffix $T_A = 25^\circ\text{C}$ Thermal Resistance	P_D $R_{\theta JA}$	625 160	W $^\circ\text{C/W}$
Operating Junction Temperature	T_J	+150	$^\circ\text{C}$
Operating Ambient Temperature Range MC34063A MC33063AV MC33063A	T_A	0 to +70 -40 to +125 -40 to +85	$^\circ\text{C}$
Storage Temperature Range	T_{stg}	-65 to +150	$^\circ\text{C}$

NOTES: 1. Maximum package power dissipation limits must be observed.
2. ESD data available upon request.

ELECTRICAL CHARACTERISTICS ($V_{CC} = 5.0\text{ V}$, $T_A = T_{low}$ to T_{high} [Note 3], unless otherwise specified.)

Characteristics	Symbol	Min	Typ	Max	Unit
OSCILLATOR					
Frequency ($V_{P_{in\ 5}} = 0\text{ V}$, $C_T = 1.0\text{ nF}$, $T_A = 25^\circ\text{C}$)	f_{osc}	24	33	42	kHz
Charge Current ($V_{CC} = 5.0\text{ V}$ to 40 V , $T_A = 25^\circ\text{C}$)	I_{chg}	24	35	42	μA
Discharge Current ($V_{CC} = 5.0\text{ V}$ to 40 V , $T_A = 25^\circ\text{C}$)	I_{dischg}	140	220	260	μA
Discharge to Charge Current Ratio (Pin 7 to V_{CC} , $T_A = 25^\circ\text{C}$)	I_{dischg}/I_{chg}	5.2	6.5	7.5	-
Current Limit Sense Voltage ($I_{chg} = I_{dischg}$, $T_A = 25^\circ\text{C}$)	$V_{ipk(\text{sense})}$	250	300	350	mV
OUTPUT SWITCH (Note 4)					
Saturation Voltage, Darlington Connection (Note 5) ($I_{SW} = 1.0\text{ A}$, Pins 1, 8 connected)	$V_{CE(\text{sat})}$	-	1.0	1.3	V
Saturation Voltage, Darlington Connection ($I_{SW} = 1.0\text{ A}$, $R_{P_{in\ 8}} = 82\ \Omega$ to V_{CC} , Forced $\beta = 20$)	$V_{CE(\text{sat})}$	-	0.45	0.7	V
DC Current Gain ($I_{SW} = 1.0\text{ A}$, $V_{CE} = 5.0\text{ V}$, $T_A = 25^\circ\text{C}$)	h_{FE}	50	75	-	-
Collector Off-State Current ($V_{CE} = 40\text{ V}$)	$I_{C(\text{off})}$	-	0.01	100	μA

NOTES: 3. $T_{low} = 0^\circ\text{C}$ for MC34063A, -40°C for MC33063A, AV $T_{high} = +70^\circ\text{C}$ for MC34063A, $+85^\circ\text{C}$ for MC33063A, $+125^\circ\text{C}$ for MC33063AV
4. Low duty cycle pulse techniques are used during test to maintain junction temperature as close to ambient temperature as possible.
5. If the output switch is driven into hard saturation (non-Darlington configuration) at low switch currents ($\leq 300\text{ mA}$) and high driver currents ($\geq 30\text{ mA}$), it may take up to $2.0\ \mu\text{s}$ for it to come out of saturation. This condition will shorten the off time at frequencies $\geq 30\text{ kHz}$, and is magnified at high temperatures. This condition does not occur with a Darlington configuration, since the output switch cannot saturate. If a non-Darlington configuration is used, the following output drive condition is recommended:

$$\text{Forced } \beta \text{ of output switch : } \frac{I_{C \text{ output}}}{I_{C \text{ driver}} - 7.0\text{ mA}^*} \geq 10$$

*The $100\ \Omega$ resistor in the emitter of the driver device requires about 7.0 mA before the output switch conducts.

MC34063A MC33063A

ELECTRICAL CHARACTERISTICS (continued) ($V_{CC} = 5.0\text{ V}$, $T_A = T_{low}$ to T_{high} [Note 3], unless otherwise specified.)

Characteristics	Symbol	Min	Typ	Max	Unit
COMPARATOR					
Threshold Voltage $T_A = 25^\circ\text{C}$ $T_A = T_{low}$ to T_{high}	V_{th}	1.225 1.21	1.25 –	1.275 1.29	V
Threshold Voltage Line Regulation ($V_{CC} = 3.0\text{ V}$ to 40 V) MC33063A, MC34063A MC33363AV	Regline	– –	1.4 1.4	5.0 6.0	mV
Input Bias Current ($V_{in} = 0\text{ V}$)	I_B	–	–20	–400	nA
TOTAL DEVICE					
Supply Current ($V_{CC} = 5.0\text{ V}$ to 40 V , $C_T = 1.0\text{ nF}$, Pin 7 = V_{CC} , $V_{Pin 5} > V_{th}$, Pin 2 = Gnd, remaining pins open)	I_{CC}	–	–	4.0	mA

- NOTES:** 3. $T_{low} = 0^\circ\text{C}$ for MC34063A, -40°C for MC33063A, AV $T_{high} = +70^\circ\text{C}$ for MC34063A, $+85^\circ\text{C}$ for MC33063A, $+125^\circ\text{C}$ for MC33063AV
 4. Low duty cycle pulse techniques are used during test to maintain junction temperature as close to ambient temperature as possible.
 5. If the output switch is driven into hard saturation (non-Darlington configuration) at low switch currents ($\leq 300\text{ mA}$) and high driver currents ($\geq 30\text{ mA}$), it may take up to $2.0\ \mu\text{s}$ for it to come out of saturation. This condition will shorten the off time at frequencies $\geq 30\text{ kHz}$, and is magnified at high temperatures. This condition does not occur with a Darlington configuration, since the output switch cannot saturate. If a non-Darlington configuration is used, the following output drive condition is recommended:

$$\text{Forced } \beta \text{ of output switch : } \frac{I_{C \text{ output}}}{I_{C \text{ driver}} - 7.0\text{ mA}^*} \geq 10$$

*The $100\ \Omega$ resistor in the emitter of the driver device requires about 7.0 mA before the output switch conducts.

Figure 1. Output Switch On–Off Time versus Oscillator Timing Capacitor

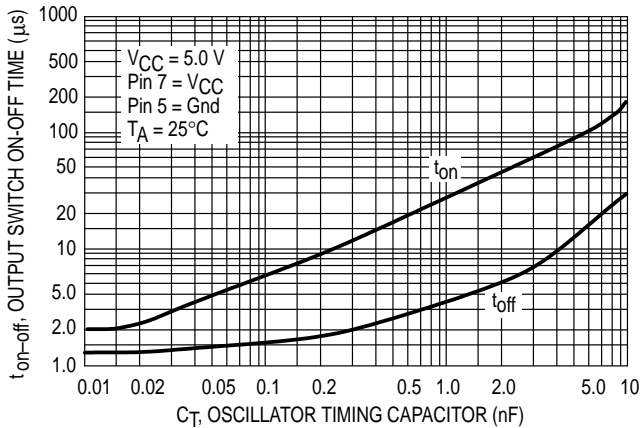

Figure 2. Timing Capacitor Waveform

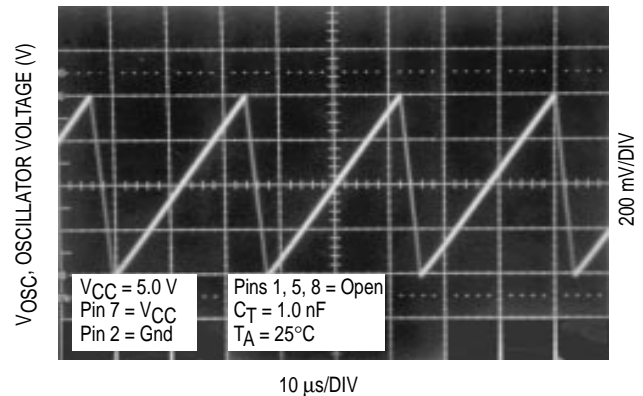

Figure 3. Emitter Follower Configuration Output Saturation Voltage versus Emitter Current

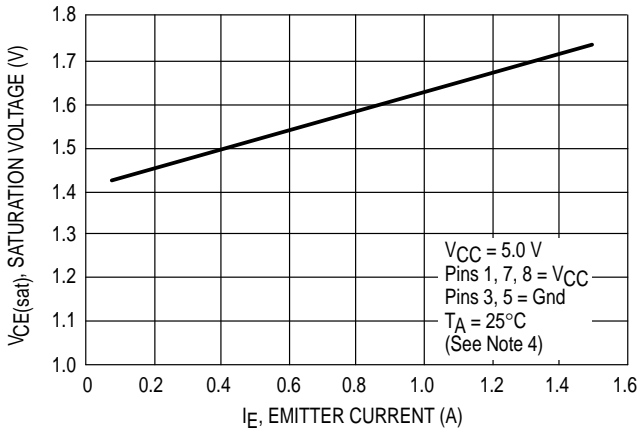

Figure 4. Common Emitter Configuration Output Switch Saturation Voltage versus Collector Current

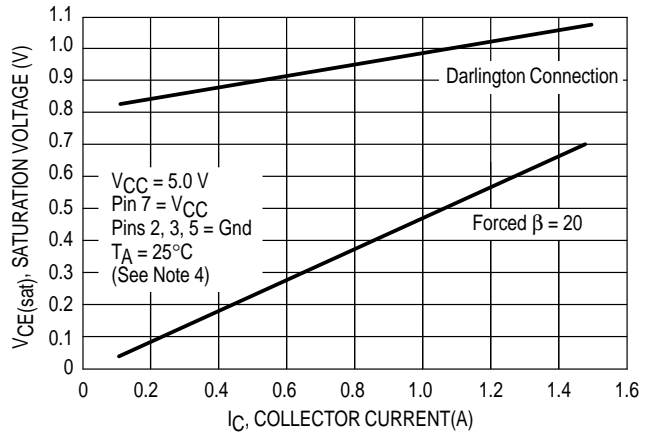

Figure 5. Current Limit Sense Voltage versus Temperature

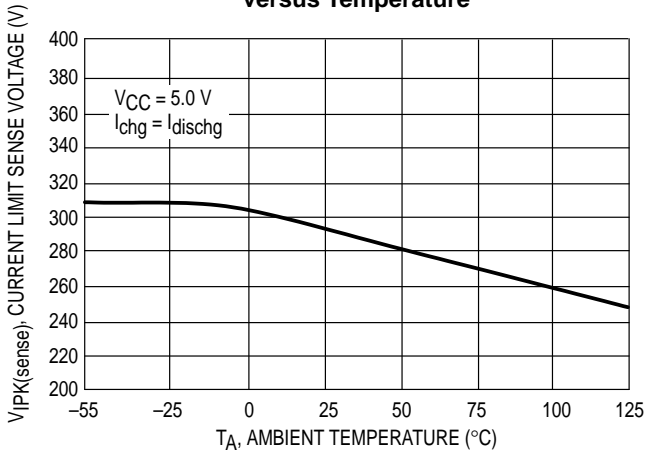
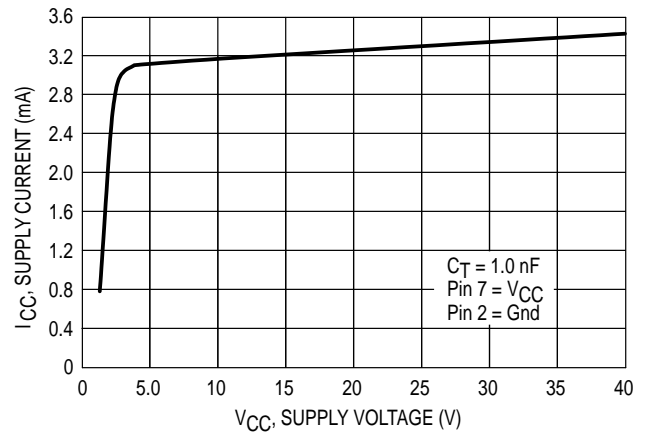

Figure 6. Standby Supply Current versus Supply Voltage



NOTE: 4. Low duty cycle pulse techniques are used during test to maintain junction temperature as close to ambient temperature as possible.

MC34063A MC33063A

Figure 7. Step-Up Converter

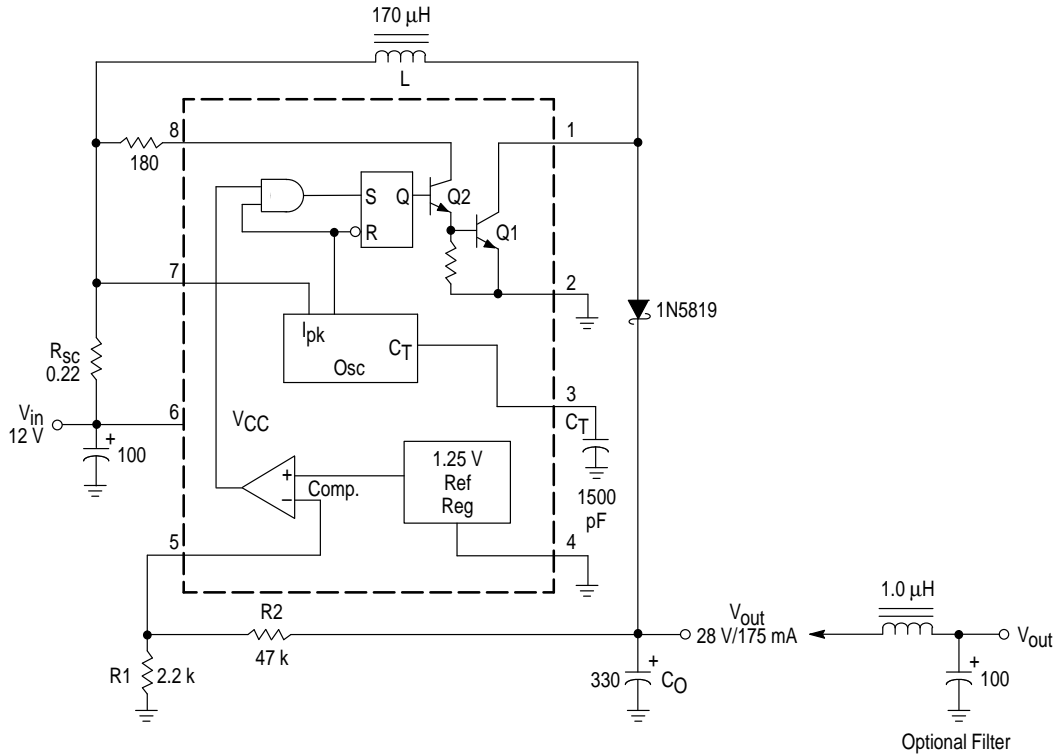

Test	Conditions	Results
Line Regulation	$V_{in} = 8.0 \text{ V to } 16 \text{ V}, I_O = 175 \text{ mA}$	$30 \text{ mV} = \pm 0.05\%$
Load Regulation	$V_{in} = 12 \text{ V}, I_O = 75 \text{ mA to } 175 \text{ mA}$	$10 \text{ mV} = \pm 0.017\%$
Output Ripple	$V_{in} = 12 \text{ V}, I_O = 175 \text{ mA}$	400 mVpp
Efficiency	$V_{in} = 12 \text{ V}, I_O = 175 \text{ mA}$	87.7%
Output Ripple With Optional Filter	$V_{in} = 12 \text{ V}, I_O = 175 \text{ mA}$	40 mVpp

Figure 8. External Current Boost Connections for I_C Peak Greater than 1.5 A

8a. External NPN Switch

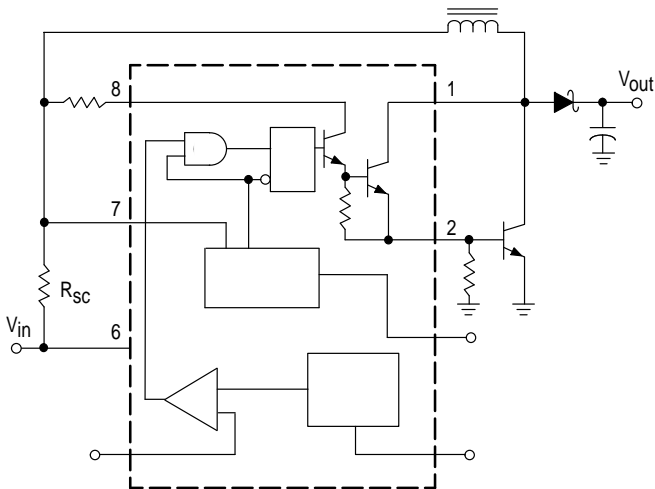

8b. External NPN Saturated Switch

(See Note 5)

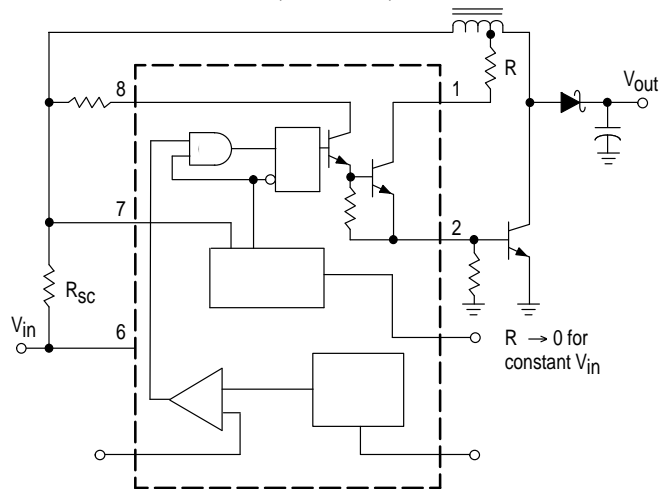

NOTE: 5. If the output switch is driven into hard saturation (non-Darlington configuration) at low switch currents ($\leq 300 \text{ mA}$) and high driver currents ($\geq 30 \text{ mA}$), it may take up to $2.0 \mu\text{s}$ to come out of saturation. This condition will shorten the off time at frequencies $\geq 30 \text{ kHz}$, and is magnified at high temperatures. This condition does not occur with a Darlington configuration, since the output switch cannot saturate. If a non-Darlington configuration is used, the following output drive condition is recommended.

MC34063A MC33063A

Figure 11. Voltage Inverting Converter

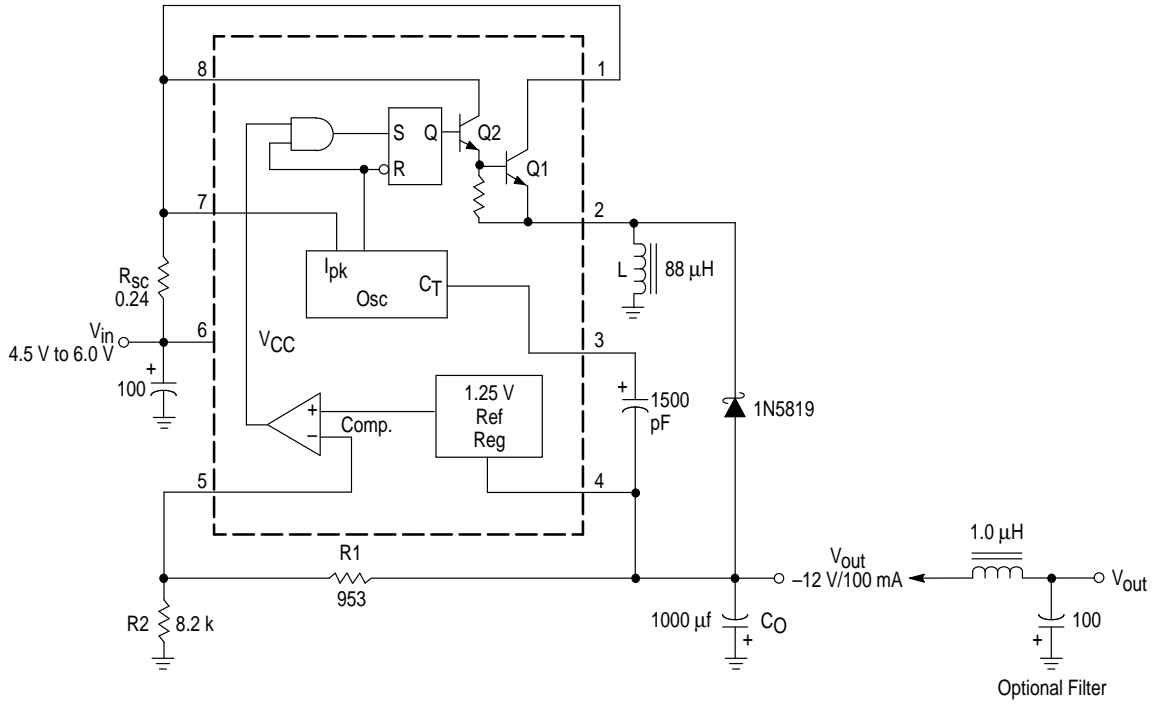

Test	Conditions	Results
Line Regulation	$V_{in} = 4.5 \text{ V to } 6.0 \text{ V}$, $I_O = 100 \text{ mA}$	$3.0 \text{ mV} = \pm 0.012\%$
Load Regulation	$V_{in} = 5.0 \text{ V}$, $I_O = 10 \text{ mA to } 100 \text{ mA}$	$0.022 \text{ V} = \pm 0.09\%$
Output Ripple	$V_{in} = 5.0 \text{ V}$, $I_O = 100 \text{ mA}$	500 mVpp
Short Circuit Current	$V_{in} = 5.0 \text{ V}$, $R_L = 0.1 \Omega$	910 mA
Efficiency	$V_{in} = 5.0 \text{ V}$, $I_O = 100 \text{ mA}$	62.2%
Output Ripple With Optional Filter	$V_{in} = 5.0 \text{ V}$, $I_O = 100 \text{ mA}$	70 mVpp

Figure 12. External Current Boost Connections for I_C Peak Greater than 1.5 A

12a. External NPN Switch

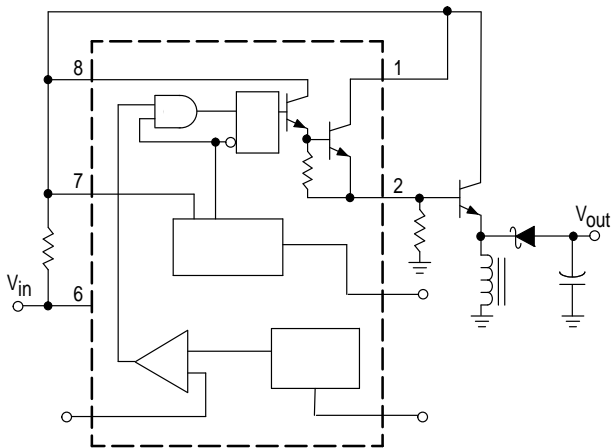

12b. External PNP Saturated Switch

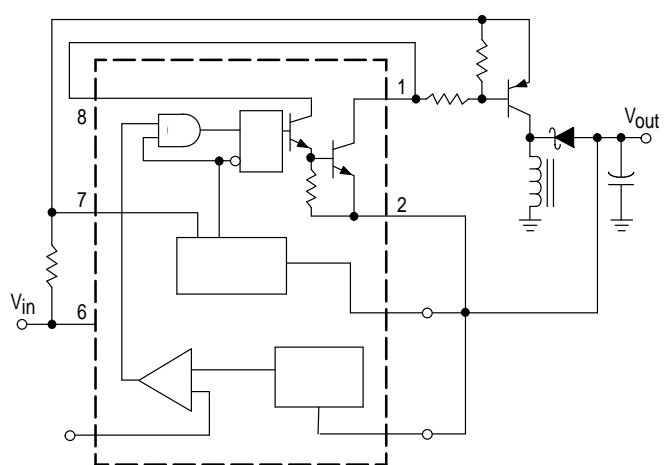

MC34063A MC33063A

Figure 13. Printed Circuit Board and Component Layout
(Circuits of Figures 7, 9, 11)

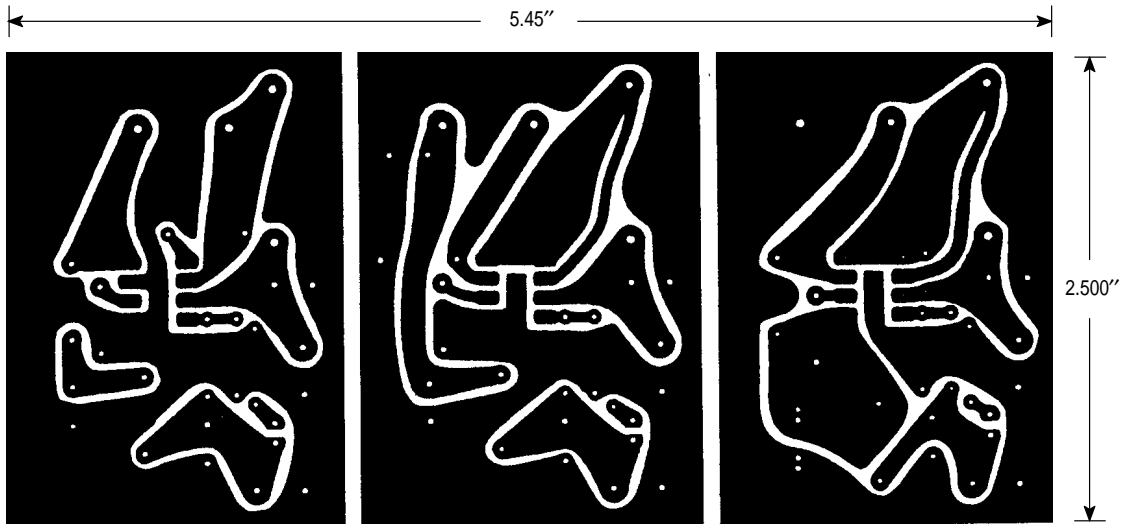

(Top view, copper foil as seen through the board from the component side)

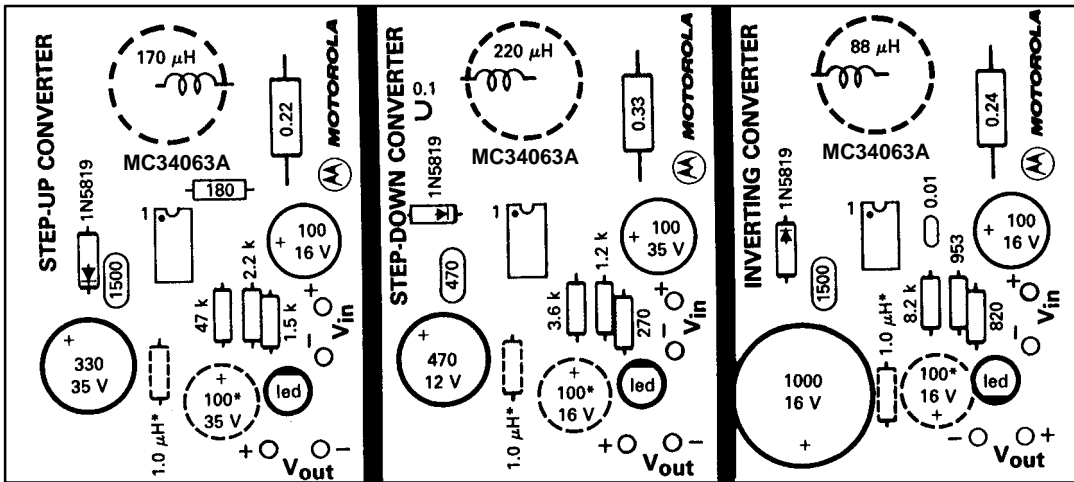

(Top View, Component Side)

*Optional Filter.

INDUCTOR DATA

Converter	Inductance (μH)	Turns/Wire
Step-Up	170	38 Turns of #22 AWG
Step-Down	220	48 Turns of #22 AWG
Voltage-Inverting	88	28 Turns of #22 AWG

All inductors are wound on Magnetics Inc. 55117 toroidal core.

Figure 14. Design Formula Table

Calculation	Step-Up	Step-Down	Voltage-Inverting
t_{on}/t_{off}	$\frac{V_{out} + V_F - V_{in(min)}}{V_{in(min)} - V_{sat}}$	$\frac{V_{out} + V_F}{V_{in(min)} - V_{sat} - V_{out}}$	$\frac{ V_{out} + V_F}{V_{in} - V_{sat}}$
$(t_{on} + t_{off})$	$\frac{1}{f}$	$\frac{1}{f}$	$\frac{1}{f}$
t_{off}	$\frac{t_{on} + t_{off}}{\frac{t_{on}}{t_{off}} + 1}$	$\frac{t_{on} + t_{off}}{\frac{t_{on}}{t_{off}} + 1}$	$\frac{t_{on} + t_{off}}{\frac{t_{on}}{t_{off}} + 1}$
t_{on}	$(t_{on} + t_{off}) - t_{off}$	$(t_{on} + t_{off}) - t_{off}$	$(t_{on} + t_{off}) - t_{off}$
C_T	$4.0 \times 10^{-5} t_{on}$	$4.0 \times 10^{-5} t_{on}$	$4.0 \times 10^{-5} t_{on}$
$I_{pk}(switch)$	$2I_{out(max)} \left(\frac{t_{on}}{t_{off}} + 1 \right)$	$2I_{out(max)}$	$2I_{out(max)} \left(\frac{t_{on}}{t_{off}} + 1 \right)$
R_{sc}	$0.3/I_{pk}(switch)$	$0.3/I_{pk}(switch)$	$0.3/I_{pk}(switch)$
$L_{(min)}$	$\left(\frac{V_{in(min)} - V_{sat}}{I_{pk}(switch)} \right) t_{on(max)}$	$\left(\frac{V_{in(min)} - V_{sat} - V_{out}}{I_{pk}(switch)} \right) t_{on(max)}$	$\left(\frac{V_{in(min)} - V_{sat}}{I_{pk}(switch)} \right) t_{on(max)}$
C_O	$9 \frac{I_{out} t_{on}}{V_{ripple(pp)}}$	$\frac{I_{pk}(switch)(t_{on} + t_{off})}{8V_{ripple(pp)}}$	$9 \frac{I_{out} t_{on}}{V_{ripple(pp)}}$

V_{sat} = Saturation voltage of the output switch.
 V_F = Forward voltage drop of the output rectifier.

The following power supply characteristics must be chosen:

V_{in} – Nominal input voltage.

V_{out} – Desired output voltage, $|V_{out}| = 1.25 \left(1 + \frac{R2}{R1} \right)$

I_{out} – Desired output current.

f_{min} – Minimum desired output switching frequency at the selected values of V_{in} and I_O .

$V_{ripple(pp)}$ – Desired peak-to-peak output ripple voltage. In practice, the calculated capacitor value will need to be increased due to its equivalent series resistance and board layout. The ripple voltage should be kept to a low value since it will directly affect the line and load regulation.

NOTE: For further information refer to Application Note AN920A/D and AN954/D.

MC34063A MC33063A

OUTLINE DIMENSIONS

P, P1 SUFFIX PLASTIC PACKAGE CASE 626-05 ISSUE K

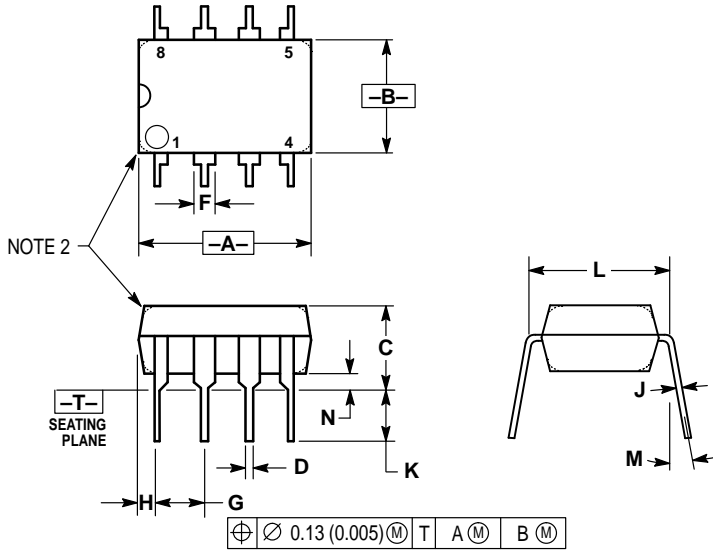

NOTES:

1. DIMENSION L TO CENTER OF LEAD WHEN FORMED PARALLEL.
2. PACKAGE CONTOUR OPTIONAL (ROUND OR SQUARE CORNERS).
3. DIMENSIONING AND TOLERANCING PER ANSI Y14.5M, 1982.

DIM	MILLIMETERS		INCHES	
	MIN	MAX	MIN	MAX
A	9.40	10.16	0.370	0.400
B	6.10	6.60	0.240	0.260
C	3.94	4.45	0.155	0.175
D	0.38	0.51	0.015	0.020
F	1.02	1.78	0.040	0.070
G	2.54 BSC		0.100 BSC	
H	0.76	1.27	0.030	0.050
J	0.20	0.30	0.008	0.012
K	2.92	3.43	0.115	0.135
L	7.62 BSC		0.300 BSC	
M	— 10°		— 10°	
N	0.76	1.01	0.030	0.040

D SUFFIX PLASTIC PACKAGE CASE 751-05 (SO-8) ISSUE P

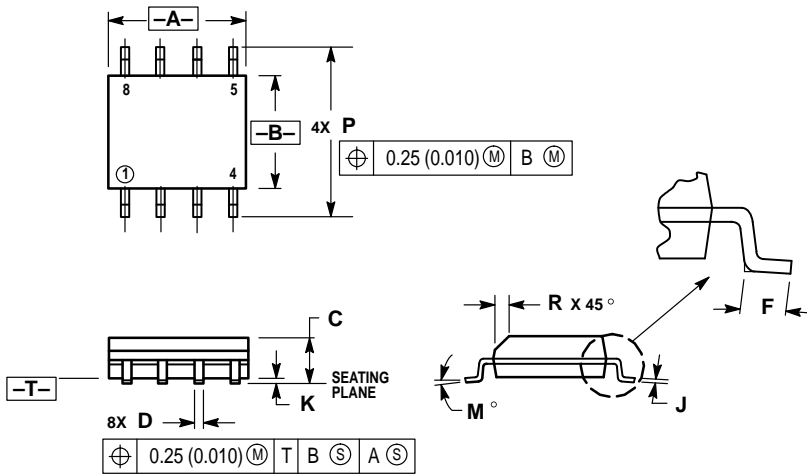

NOTES:

1. DIMENSIONING AND TOLERANCING PER ANSI Y14.5M, 1982.
2. CONTROLLING DIMENSION: MILLIMETER.
3. DIMENSIONS A AND B DO NOT INCLUDE MOLD PROTRUSION.
4. MAXIMUM MOLD PROTRUSION 0.15 (0.006) PER SIDE.
5. DIMENSION D DOES NOT INCLUDE DAMBAR PROTRUSION. ALLOWABLE DAMBAR PROTRUSION SHALL BE 0.127 (0.005) TOTAL IN EXCESS OF THE D DIMENSION AT MAXIMUM MATERIAL CONDITION.

DIM	MILLIMETERS		INCHES	
	MIN	MAX	MIN	MAX
A	4.80	5.00	0.189	0.196
B	3.80	4.00	0.150	0.157
C	1.35	1.75	0.054	0.068
D	0.35	0.49	0.014	0.019
F	0.40	1.25	0.016	0.049
G	1.27 BSC		0.050 BSC	
J	0.18	0.25	0.007	0.009
K	0.10	0.25	0.004	0.009
M	0° 7°		0° 7°	
P	5.80	6.20	0.229	0.244
R	0.25	0.50	0.010	0.019

MC34063A MC33063A
NOTES

MC34063A MC33063A

Motorola reserves the right to make changes without further notice to any products herein. Motorola makes no warranty, representation or guarantee regarding the suitability of its products for any particular purpose, nor does Motorola assume any liability arising out of the application or use of any product or circuit, and specifically disclaims any and all liability, including without limitation consequential or incidental damages. "Typical" parameters which may be provided in Motorola data sheets and/or specifications can and do vary in different applications and actual performance may vary over time. All operating parameters, including "Typicals" must be validated for each customer application by customer's technical experts. Motorola does not convey any license under its patent rights nor the rights of others. Motorola products are not designed, intended, or authorized for use as components in systems intended for surgical implant into the body, or other applications intended to support or sustain life, or for any other application in which the failure of the Motorola product could create a situation where personal injury or death may occur. Should Buyer purchase or use Motorola products for any such unintended or unauthorized application, Buyer shall indemnify and hold Motorola and its officers, employees, subsidiaries, affiliates, and distributors harmless against all claims, costs, damages, and expenses, and reasonable attorney fees arising out of, directly or indirectly, any claim of personal injury or death associated with such unintended or unauthorized use, even if such claim alleges that Motorola was negligent regarding the design or manufacture of the part. Motorola and  are registered trademarks of Motorola, Inc. Motorola, Inc. is an Equal Opportunity/Affirmative Action Employer.

How to reach us:

USA/EUROPE/Locations Not Listed: Motorola Literature Distribution;
P.O. Box 20912; Phoenix, Arizona 85036. 1-800-441-2447 or 602-303-5454

MFAX: RMFAX0@email.sps.mot.com – TOUCHTONE 602-244-6609
INTERNET: <http://Design-NET.com>

JAPAN: Nippon Motorola Ltd.; Tatsumi-SPD-JLDC, 6F Seibu-Butsuryu-Center,
3-14-2 Tatsumi Koto-Ku, Tokyo 135, Japan. 03-81-3521-8315

ASIA/PACIFIC: Motorola Semiconductors H.K. Ltd.; 8B Tai Ping Industrial Park,
51 Ting Kok Road, Tai Po, N.T., Hong Kong. 852-26629298



MC34063A/D



Copyright © Each Manufacturing Company.

All Datasheets cannot be modified without permission.

This datasheet has been download from :

www.AllDataSheet.com

100% Free DataSheet Search Site.

Free Download.

No Register.

Fast Search System.

www.AllDataSheet.com