

DM74ALS245A Octal TRI-STATE® Bus Transceiver

General Description

This advanced low power Schottky device contains 8 pairs of TRI-STATE logic elements configured as octal bus transceivers. These circuits are designed for use in memory, microprocessor systems and in asynchronous bidirectional data buses. Two way communication between buses is controlled by the (DIR) input. Data transmits either from the A bus to the B bus or from the B bus to the A bus. Both the driver and receiver outputs can be disabled via the (\bar{G}) enable input which causes outputs to enter the high impedance mode so that the buses are effectively isolated.

Features

- Advanced oxide-isolated, ion-implanted Schottky TTL process
- Non-inverting logic output
- Glitch free bus during power up and down
- TRI-STATE outputs independently controlled on A and B buses
- Low output impedance to drive terminated transmission lines to 133Ω
- Switching response specified into $500\Omega/50\text{ pF}$
- Specified to interface with CMOS at $V_{OH} = V_{CC} - 2V$
- PNP inputs to reduce input loading
- Switching specifications guaranteed over full temperature and V_{CC} range

Connection Diagram

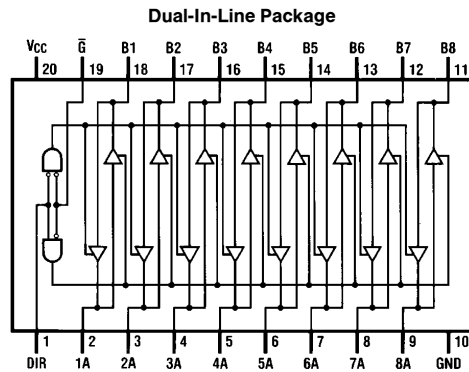

TL/F/6213-1

Order Number DM74ALS245MSA, DM74ALS245AWM, DM74ALS245AN or DM74ALS245ASJ
See NS Package Number M20B, M20D, MQA20 or N20A

Function Table

Control Inputs		Operation
\bar{G}	DIR	
L	L	B Data to A Bus
L	H	A Data to B Bus
H	X	Hi-Z

H = High Logic Level
L = Low Logic Level
X = Either High or Low Logic Level

TRI-STATE® is a registered trademark of National Semiconductor Corporation.

Absolute Maximum Ratings

Supply Voltage	7V
Input Voltage	
Control Inputs	7V
I/O Ports	5.5V
Operating Free Air Temperature Range	
DM74ALS	0°C to +70°C
Storage Temperature Range	−65°C to +150°C
Typical θ_{JA}	
N Package	53.0°C/W
M Package	72.0°C/W

Note: The “Absolute Maximum Ratings” are those values beyond which the safety of the device cannot be guaranteed. The device should not be operated at these limits. The parametric values defined in the “Electrical Characteristics” table are not guaranteed at the absolute maximum ratings. The “Recommended Operating Conditions” table will define the conditions for actual device operation.

Recommended Operating Conditions

Symbol	Parameter	DM74ALS245A			Units
		Min	Typ	Max	
V_{CC}	Supply Voltage	4.5	5	5.5	V
V_{IH}	High Level Input Voltage	2			V
V_{IL}	Low Level Input Voltage			0.8	V
I_{OH}	High Level Output Current			−15	mA
I_{OL}	Low Level Output Current			24	mA
T_A	Operating Free Air Temperature	0		70	°C

Electrical Characteristics

over recommended operating free air temperature range. All typical values are measured at $V_{CC} = 5V$, $T_A = 25^\circ C$.

Symbol	Parameter	Conditions	Min	Typ	Max	Units
V_{IK}	Input Clamp Voltage	$V_{CC} = 4.5V$, $I_{IN} = -18\text{ mA}$			−1.5	V
V_{OH}	High Level Output Voltage	$V_{CC} = 4.5V$, $I_{OH} = -3\text{ mA}$	2.4	3.2		V
		$V_{CC} = 4.5V$, $I_{OH} = \text{Max}$	2	2.3		V
		$I_{OH} = -0.4\text{ mA}$, $V_{CC} = 4.5V\text{ to }5.5V$	$V_{CC} - 2$			V
V_{OL}	Low Level Output Voltage	$V_{CC} = 4.5V$, $I_{OL} = 24\text{ mA}$		0.35	0.5	V
I_I	Input Current at Max Input Voltage	$V_{CC} = 5.5V$, $V_{IN} = 7V$, Control Inputs			0.1	mA
		$V_{CC} = 5.5V$, $V_{IN} = 5.5V$, A or B Ports			0.1	
I_{IH}	High Level Input Current	$V_{CC} = 5.5V$, $V_{IN} = 2.7V$			20	μA
I_{IL}	Low Level Input Current	$V_{CC} = 5.5V$, $V_{IN} = 0.4V$			−0.1	mA
I_O	Output Drive Current	$V_{CC} = 5.5V$, $V_{OUT} = 2.25V$	−30		−112	mA
I_{CC}	Supply Current	$V_{CC} = 5.5V$, Outputs High		30	45	mA
		$V_{CC} = 5.5V$, Outputs Low		36	55	mA
		$V_{CC} = 5.5V$, TRI-STATE		38	58	mA

Switching Characteristics over recommended operating free air temperature range (Notes 1 and 2)

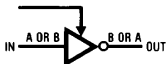
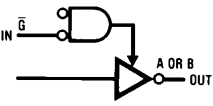
Symbol	Parameter	Circuit Configuration	DM74ALS245A		Units
			Min	Max	
t_{PLH}	Propagation Delay Time Low-to-High Level Output		3	10	ns
t_{PHL}	Propagation Delay Time High-to-Low Level Output		3	10	ns
t_{PZL}	Output Enable Time to Low Level		5	20	ns
t_{PZH}	Output Enable Time to High Level		5	20	ns
t_{PLZ}	Output Disable Time from Low Level		4	15	ns
t_{PHZ}	Output Disable Time from High Level		2	10	ns

Note 1: See Section 5 for test waveforms and output load.

Note 2: Switching characteristic conditions are $V_{CC} = 4.5V$ to $5.5V$, $R_L = 500\Omega$, $C_L = 50$ pF.

Physical Dimensions inches (millimeters)

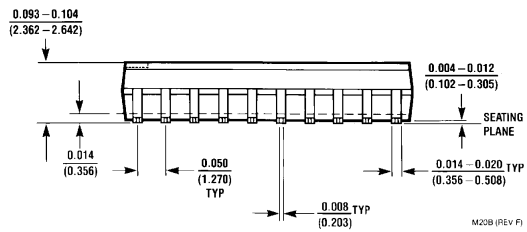
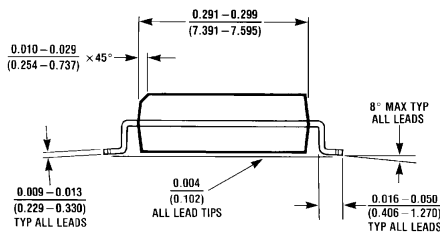
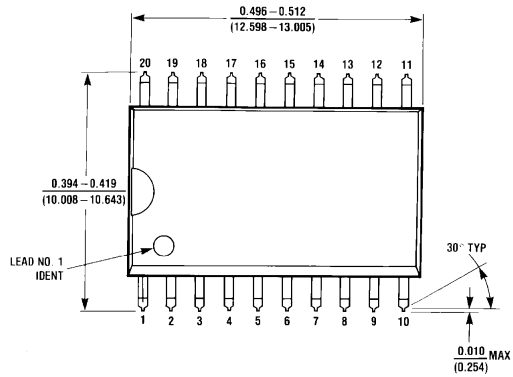

20-Lead (0.300" Wide) Small Outline Package (M)
Order Number DM74ALS245MSA or DM74ALS245AWM
NS Package Number M20B

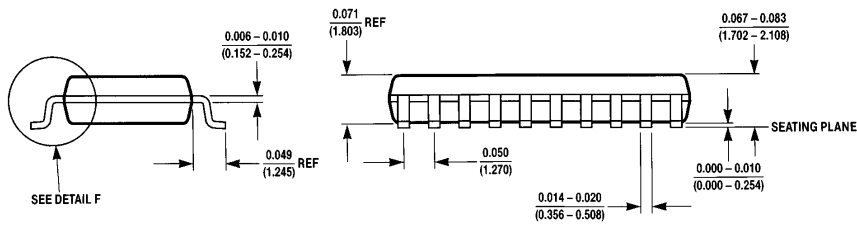
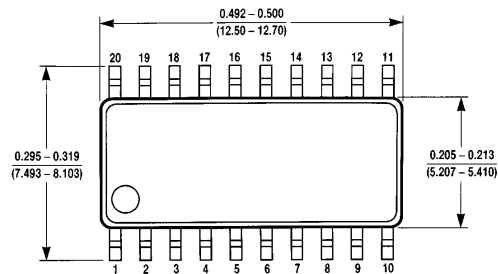
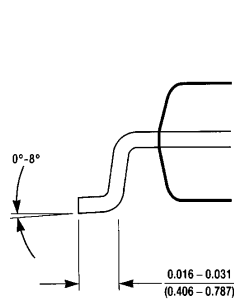

20-Lead Small Output Package-EIAJ (SJ)
Order Number DM74ALS245ASJ
NS Package Number M20D

Physical Dimensions inches (millimeters) (Continued)

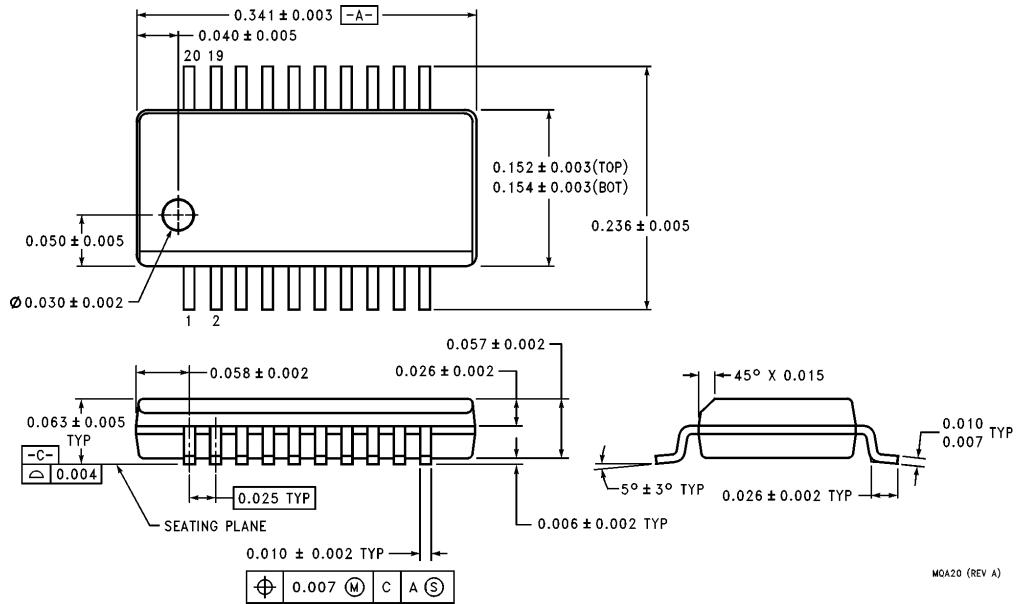

MQA20 (REV A)

**20-Lead (0.150" Wide) Shrink Small Outline Package, JEDEC
NS Package Number MQA20**

